

CERTIFICATE OF OWNERSHIP AND DEDICATION

STATE OF TEXAS
COUNTY OF BRAZOS
I, JESSE C. WALL III, THE OWNER AND DEVELOPER OF THE LAND SHOWN ON THIS PLAT, BEING PART OF THE TRACT OF LAND AS CONVEYED TO ME IN VOLUME 17686, PAGE 225 OF THE OFFICIAL PUBLIC RECORDS OF BRAZOS COUNTY, TEXAS, AND WHOSE NAME IS SUBSCRIBED HERETO, HEREBY DEDICATE TO THE USE OF THE PUBLIC FOREVER ALL STREETS, ALLEYS, PARKS, WATERCOURSES, DRAINS, EASEMENTS AND PUBLIC PLACES HEREON SHOWN FOR THE PURPOSES IDENTIFIED.

BEFORE ME, THE UNDERSIGNED AUTHORITY, ON THIS DAY PERSONALLY APPEARED JESSE C. WALL III, KNOWN TO ME TO BE THE PERSON WHOSE NAME IS SUBSCRIBED TO THE FOREGOING INSTRUMENT, AND ACKNOWLEDGED TO ME THAT HE EXECUTED THE SAME FOR THE PURPOSES STATED.

GIVEN UNDER MY HAND AND SEAL OF OFFICE THIS DAY OF 20__

NOTARY PUBLIC, BRAZOS COUNTY, TEXAS

CERTIFICATE OF SURVEY
THIS IS TO CERTIFY THAT I, CHAD A. GULICK, A REGISTERED PROFESSIONAL LAND SURVEYOR OF THE STATE OF TEXAS, HAVE PLATTED THE ABOVE SUBDIVISION FROM AN ACTUAL SURVEY ON THE GROUND; AND THAT ALL BLOCK CORNERS, LOT CORNERS, ANGLE POINTS AND POINTS OF CURVE ARE PROPERLY MARKED WITH SUITABLE MONUMENTS SET WITH THE HEAD FLUSH WITH THE GROUND OR SIDEWALKS; AND THAT THIS PLAT CORRECTLY REPRESENTS THAT SURVEY MADE BY ME.

PRELIMINARY
This document shall not be recorded for any purpose and shall not be used or viewed or relied upon as a final survey document.

CHAD A. GULICK
REGISTERED PROFESSIONAL LAND SURVEYOR
TEXAS REGISTRATION NO. 6021
TEXAS SURVEY FIRM NO. 10194550

CERTIFICATION BY THE COUNTY CLERK
I, COUNTY CLERK OF BRAZOS COUNTY, TEXAS, DO HEREBY CERTIFY THAT THE ATTACHED PLAT TOGETHER WITH ITS CERTIFICATES OF AUTHENTICATION WAS FILED ON THE DAY OF 20__ IN THE OFFICIAL RECORDS OF BRAZOS COUNTY, TEXAS.

APPROVAL OF THE PLANNING AND ZONING COMMISSION
I, CHAIR OF THE PLANNING AND ZONING COMMISSION OF THE CITY OF BRYAN, STATE OF TEXAS, HEREBY CERTIFY THAT THE ATTACHED PLAT WAS DULY FILED FOR APPROVAL WITH THE PLANNING AND ZONING COMMISSION OF THE CITY OF BRYAN ON THE DAY OF 20__ BY SAID COMMISSION.

APPROVAL OF THE CITY ENGINEER
I, THE UNDERSIGNED, CITY ENGINEER OF THE CITY OF BRYAN, HEREBY CERTIFY THAT THIS PLAT IS IN COMPLIANCE WITH THE APPROPRIATE CODES AND ORDINANCES OF THE CITY OF BRYAN AND WAS APPROVED ON THE DAY OF 20__

APPROVAL OF THE CITY PLANNER
I, THE UNDERSIGNED, CITY PLANNER AND/OR DESIGNATED SECRETARY OF THE PLANNING AND ZONING COMMISSION OF THE CITY OF BRYAN, HEREBY CERTIFY THAT THIS PLAT IS IN COMPLIANCE WITH THE APPROPRIATE CODES AND ORDINANCES OF THE CITY OF BRYAN AND WAS APPROVED ON THE DAY OF 20__

CITY ENGINEER, BRYAN, TEXAS

CITY PLANNER, BRYAN, TEXAS

T.J. WOOTEN SURVEY
ABSTRACT NO. 59

FOXWOOD CROSSING PHASE 1 VOL. 17420, PG. 53, O.P.R.B.C.T.

FOXWOOD CROSSING PHASE 2 VOL. 17902, PG. 238, O.P.R.B.C.T.

FOXWOOD CROSSING PHASE 1 VOL. 17420, PG. 53, O.P.R.B.C.T.

FOXWOOD CROSSING PHASE 1 VOL. 17420, PG. 53, O.P.R.B.C.T.

FOXWOOD CROSSING PHASE 1 VOL. 17420, PG. 53, O.P.R.B.C.T.

FOXWOOD CROSSING PHASE 1 VOL. 17420, PG. 53, O.P.R.B.C.T.

FOXWOOD CROSSING PHASE 1 VOL. 17420, PG. 53, O.P.R.B.C.T.

LEGAL DESCRIPTION OF SUBDIVISION:
BEING A 12.192-ACRE TRACT CONTAINED WITHIN THE T.J. WOOTEN SURVEY, ABSTRACT NO. 59, BRAZOS COUNTY, TEXAS, AND BEING PART OF THAT CERTAIN CALLED 45.5618-ACRE TRACT AS CONVEYED TO JESSE C. WALL III IN A GENERAL WARRANTY DEED RECORDED IN VOLUME 17686, PAGE 225, OFFICIAL PUBLIC RECORDS OF BRAZOS COUNTY, TEXAS (O.P.R.B.C.T.), SAID 12.192-ACRE TRACT BEING MORE PARTICULARLY DESCRIBED BELOW:
BEGINNING AT A 1/2-INCH IRON ROD FOUND FOR THE WESTERNMOST CORNER OF SAID 45.5618-ACRE TRACT, BEING AT THE NORTHERNMOST CORNER OF THAT CERTAIN CALLED 19.997-ACRE TRACT AS CONVEYED TO WALL DEVELOPMENT, LLC AS TRACT 1 IN A SPECIAL WARRANTY DEED RECORDED IN VOLUME 16684, PAGE 155, O.P.R.B.C.T., THE EASTERNMOST SOUTHEAST CORNER OF THAT CERTAIN CALLED 20.803-ACRE TRACT AS CONVEYED TO REALSPIN INVESTMENT TRUST IN A WARRANTY DEED WITH VENDORS LIEN RECORDED IN VOLUME 12330, PAGE 14, O.P.R.B.C.T., AND THE NORTHEAST CORNER OF LOT 1, BLOCK 1 OF JONES ROAD BUSINESS PARK AS RECORDED IN VOLUME 14082, PAGE 208, O.P.R.B.C.T.;
THENCE N 41° 49' 24" E, A DISTANCE OF 263.47 FEET, ALONG THE COMMON LINE OF SAID 45.5618-ACRE TRACT AND SAID 20.803-ACRE TRACT, TO A 1/2-INCH IRON ROD FOUND WITH CAP STAMPED "C" INCLURE RPL 5 8650" AT THE EASTERNMOST CORNER OF SAID 20.803-ACRE TRACT AND THE SOUTHERNMOST CORNER OF THAT CERTAIN CALLED 4.97-ACRE TRACT AS CONVEYED TO ROBERT JACKSON AND LAURELLE E. JACKSON IN A GENERAL WARRANTY DEED RECORDED IN VOLUME 12247, PAGE 85, O.P.R.B.C.T.;
THENCE N 42° 17' 44" E, A DISTANCE OF 188.94 FEET, ALONG THE COMMON LINE OF SAID 45.5618-ACRE TRACT AND SAID 4.97-ACRE TRACT, TO A 1/2-INCH IRON ROD FOUND AT THE EASTERNMOST CORNER OF SAID 4.97-ACRE TRACT AND THE SOUTHERNMOST CORNER OF THAT CERTAIN CALLED 5.28-ACRE TRACT AS CONVEYED TO ROBERT C. JACKSON AND ELAIN L. JACKSON IN A WARRANTY DEED WITH VENDORS LIEN RECORDED IN VOLUME 879, PAGE 435, O.P.R.B.C.T.;
THENCE N 42° 12' 54" E, A DISTANCE OF 456.52 FEET, ALONG THE NORTHWEST LINE OF SAID 45.5618-ACRE TRACT, TO A 5/8-INCH IRON ROD WITH CAP STAMPED "COLLIERS PROP COR" FOUND ON THE COMMON LINE OF SAID 45.5618-ACRE TRACT AND THAT CERTAIN CALLED 19.76-ACRE TRACT AS CONVEYED TO GRABER WYATT FAMILY TRUST IN A SPECIAL WARRANTY DEED RECORDED IN VOLUME 14415, PAGE 126, O.P.R.B.C.T.;
THENCE N 47° 51' 58" W, A DISTANCE OF 327.99 FEET, ALONG THE COMMON LINE OF SAID 45.5618-ACRE TRACT AND SAID FOXWOOD CROSSING PHASE 1, TO THE NORTHERNMOST CORNER OF SAID FOXWOOD CROSSING PHASE 1 AND THE EASTERNMOST CORNER OF SAID 19.997-ACRE TRACT, FROM WHICH A FOUND 1/2-INCH IRON ROD BEARS S 01° 15' 33" W, A DISTANCE OF 0.91 FEET;
THENCE N 45° 17' 08" W, A DISTANCE OF 789.73 FEET, ALONG THE COMMON LINE OF SAID 45.5618-ACRE TRACT AND SAID 19.997-ACRE TRACT, TO THE POINT OF BEGINNING, AND CONTAINING 12.392 ACRES OF LAND, MORE OR LESS.

- GENERAL NOTES
1. ALL BEARINGS AND COORDINATES ARE BASED ON THE TEXAS COORDINATE SYSTEM, CENTRAL ZONE (4203) NAD 83, EPOCH 2010.00.
2. ACCORDING TO THE NATIONAL FLOOD INSURANCE PROGRAM FLOOD INSURANCE RATE MAPS FOR BRAZOS COUNTY, TEXAS, MAP NUMBER 48041C0285, PANEL 0285E, DATED MAY 16, 2012, ALL OF THIS PROPERTY IS LOCATED WITHIN UNSHADED ZONE "X", AREA OF MINIMAL FLOOD HAZARD.
3. PER CITY OF BRYAN ORDINANCE NO. 2252, THIS PROPERTY HAS BEEN ANNEXED INTO THE CITY OF BRYAN ON APRIL 12, 2022.
4. THE BUILDING SETBACK REQUIREMENTS FOR THIS TRACT ARE ESTABLISHED BY THE CITY OF BRYAN ORDINANCES SEC. 62-161.
5. SANITARY SEWER: SANITARY SEWER SERVICE FOR THIS SUBDIVISION SHALL BE PROVIDED BY THE EXTENSION OF THE EXISTING CITY OF BRYAN SANITARY SEWER INFRASTRUCTURE ALONG JONES ROAD, 979-209-5030.
6. DOMESTIC WATER SERVICE: THE DOMESTIC WATER SERVICE FOR THIS SUBDIVISION SHALL BE PROVIDED BY THE CITY OF BRYAN, 979-209-5030.
7. ELECTRICAL SERVICE: BRYAN TEXAS UTILITIES (BTU) SHALL BE PROVIDING ELECTRICAL SERVICE TO THIS SUBDIVISION, 979-823-5784.
8. ALL PUBLIC UTILITY EASEMENTS (PUE) SHOWN HEREON SHALL BE DEDICATED WITH THE PLATTING OF THIS SUBDIVISION.
9. WHERE ELECTRIC FACILITIES ARE INSTALLED, BTU HAS THE RIGHT TO INSTALL, OPERATE, RELOCATE, CONSTRUCT, RECONSTRUCT, ADD TO, MAINTAIN, INSPECT, PATROL, ENFORCE, REPAIR, REMOVE, AND REPLACE SAID FACILITIES UPON, OVER, UNDER, AND ACROSS THE PROPERTY INCLUDED IN THE PUE, AND THE RIGHT OF INGRESS AND EGRESS ON PROPERTY ADJACENT TO THE PUE TO ACCESS ELECTRIC FACILITIES.
10. DRIVERSWAYS WILL BE LOCATED AND CONSTRUCTED IN ACCORDANCE WITH RGS GUIDELINES.
11. ALL DEVELOPMENT AND CONSTRUCTION SHALL BE IN ACCORDANCE WITH THE CITY OF BRYAN STANDARDS, ORDINANCES AND REGULATIONS.
12. THE CITY OF BRYAN IS RESPONSIBLE FOR THE MAINTENANCE OF FACILITIES WITHIN THE R.O.W. AND WITHIN PUBLIC UTILITY AND DRAINAGE EASEMENTS.
13. A HOMEOWNER'S ASSOCIATION (HOA) SHALL BE ESTABLISHED WITH DIRECT RESPONSIBILITY TO, AND CONTROLLED BY, THE PROPERTY OWNERS INVOLVED TO PROVIDE FOR OPERATION, REPAIR AND MAINTENANCE OF ALL COMMON AREAS, PRIVATE DRAINAGE EASEMENTS, AND PRIVATE STORMWATER DETENTION FACILITIES WHICH ARE PART OF THIS SUBDIVISION. THE CITY OF BRYAN SHALL NOT BE RESPONSIBLE FOR ANY OPERATION, REPAIR AND MAINTENANCE OF THESE AREAS. HOA TO MAINTAIN ALL COMMON AREAS, SIDEWALKS, STORM SEWER, DRAINAGE AND DETENTION AREAS WITHIN PRIVATE DRAINAGE EASEMENTS.

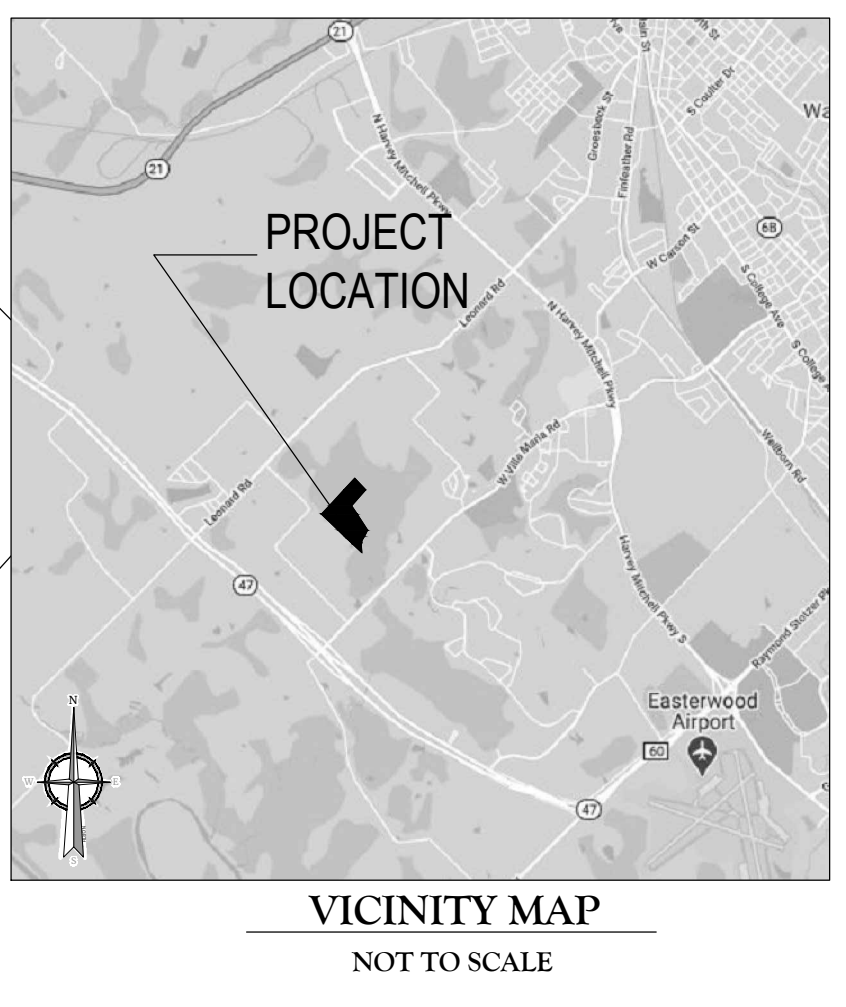
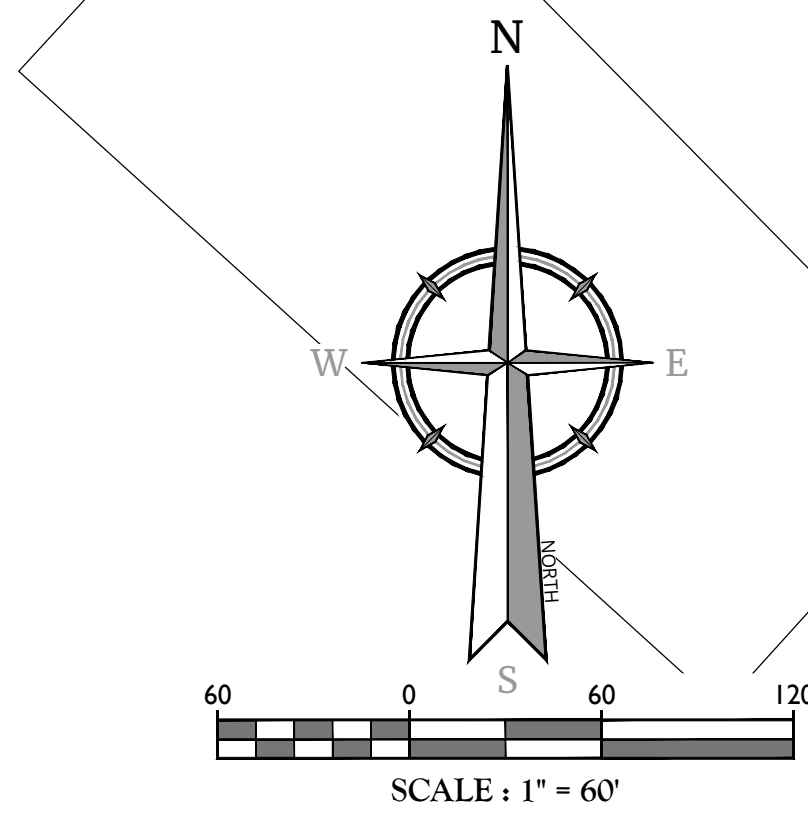
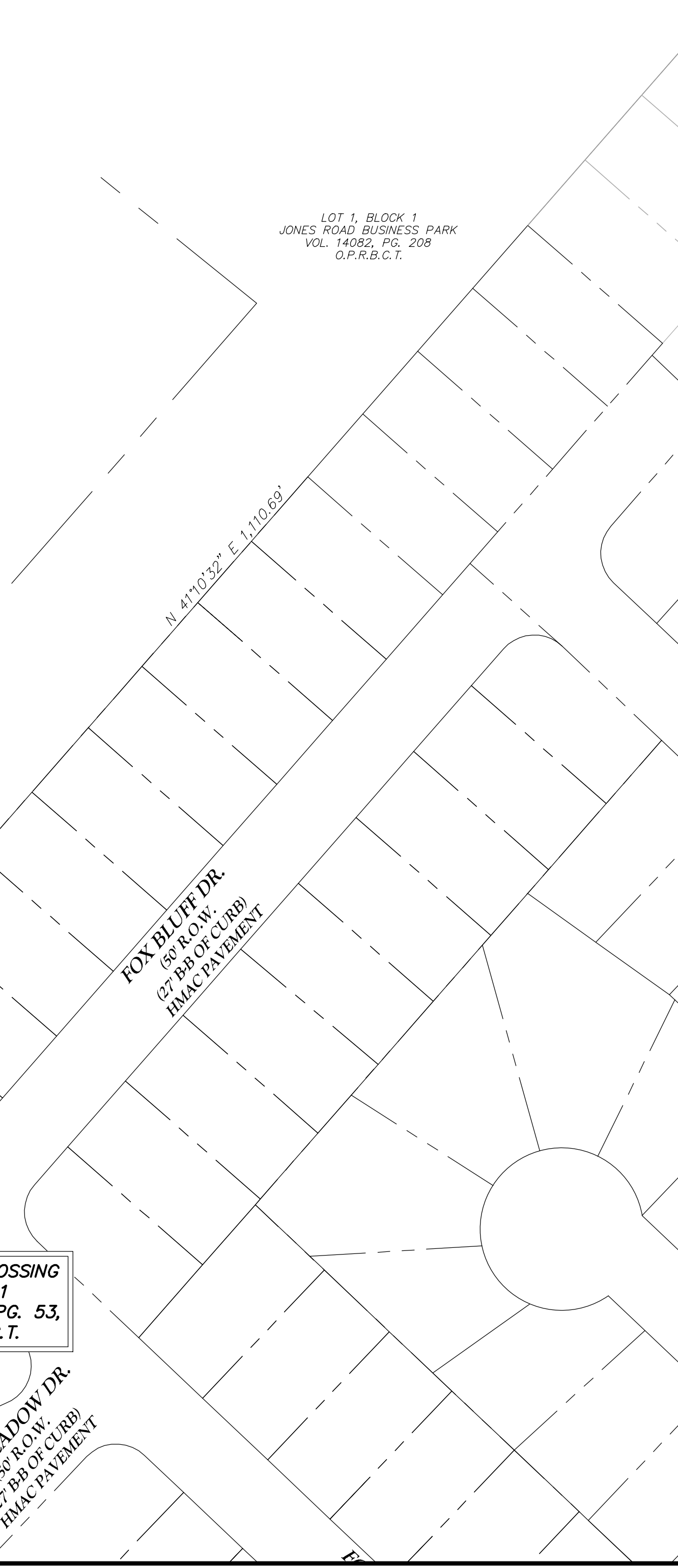

LOT TABLE
LOT NUMBER, LOT AREA (SQ. FT.), LOT DEPTH (FT.), LOT WIDTH (FT.)
1 2,900 109.90 55.05
2 3,900 109.90 55.05
3 5,911 109.32 54.07
4 5,905 109.04 54.07
5 5,889 108.78 54.07
6 5,855 107.99 54.07
7 5,770 106.71 54.07
8 5,705 105.50 54.08
9 5,642 104.36 54.08
10 5,588 103.34 54.08
11 5,536 102.37 54.08
12 5,483 101.39 53.68
13 5,431 100.46 53.68
14 5,380 99.53 53.68
15 5,330 98.64 53.68
16 5,281 97.74 53.68
17 5,233 96.89 53.68
18 5,186 96.04 53.68
19 5,140 95.18 53.68
20 5,095 94.36 53.68
21 5,051 93.53 53.68
22 5,008 92.74 53.68
23 4,967 91.94 53.68
24 4,927 91.18 53.68
25 4,888 90.46 53.68
26 4,850 89.74 53.68
27 4,813 89.06 53.68
28 4,777 88.43 53.68
29 4,742 87.78 53.68
30 4,708 87.16 53.68
31 4,675 86.57 53.68
32 4,643 86.01 53.68
33 4,612 85.48 53.68
34 4,582 84.97 53.68
35 4,553 84.49 53.68
36 4,525 84.03 53.68
37 4,498 83.60 53.68
38 4,472 83.19 53.68
39 4,447 82.81 53.68
40 4,423 82.45 53.68
41 4,400 82.11 53.68
42 4,378 81.79 53.68
43 4,357 81.49 53.68
44 4,337 81.20 53.68
45 4,318 80.93 53.68
46 4,300 80.68 53.68
47 4,283 80.44 53.68
48 4,267 80.21 53.68
49 4,252 80.00 53.68
50 4,238 79.80 53.68
51 4,225 79.61 53.68
52 4,213 79.43 53.68
53 4,202 79.26 53.68
54 4,192 79.10 53.68
55 4,183 78.95 53.68
56 4,175 78.81 53.68
57 4,168 78.68 53.68

LINE DATA
SEGMENT, DIRECTION, LENGTH
L1 N 42° 08' 04" E 96.42'
L2 N 46° 17' 08" W 238.31'
L3 S 57° 43' 10" E 65.57'
L4 N 43° 42' 52" E 138.30'
L5 N 70° 34' 48" E 50.00'
L6 N 75° 46' 21" E 46.20'
L7 S 27° 55' 33" W 41.61'
L8 S 21° 55' 35" W 52.32'
L9 S 12° 54' 20" W 37.94'
L10 S 9° 44' 42" W 14.50'
L11 S 1° 38' 20" W 8.92'

CURVE DATA
SEGMENT, RADIUS, LENGTH, DELTA, CHORD
C2 75.00' 115.92' 88° 33' 34" S 2° 08' 44" E 104.72'
C3 25.00' 39.27' 90° 00' 00" S 1° 17' 08" E 35.36'
C4 30.00' 24.38' 46° 34' 03" S 66° 59' 53" W 23.72'
C5 50.00' 238.36' 273° 08' 06" S 46° 17' 08" E 68.75'
C6 30.30' 24.37' 46° 04' 37" N 20° 25' 52" E 23.72'
C7 29.90' 26.82' 55° 12' 57" N 70° 37' 21" E 27.72'
C8 40.00' 137.91' 197° 32' 32" N 0° 38' 30" W 79.06'
C9 30.00' 27.82' 53° 08' 01" N 72° 50' 49" W 26.83'
C10 23.82' 39.11' 94° 05' 39" N 2° 04' 32" W 34.86'
C11 50.00' 77.31' 88° 35' 29" N 2° 09' 40" W 69.84'
C12 50.00' 78.54' 90° 00' 00" N 1° 17' 08" W 70.71'
C14 30.12' 28.93' 55° 02' 02" N 84° 47' 41" E 27.83'

- LEGEND
- ADJACENT BOUNDARY
- ACRES
- BUILDING (SETBACK) LINE
- IRON PIPE FOUND
- IRON ROD FOUND
- PUBLIC UTILITY EASEMENT (10' UNLESS OTHERWISE NOTED)
- RIGHT OF WAY
- SQUARE FEET
- OFFICIAL PUBLIC RECORDS OF BRAZOS COUNTY, TEXAS
- BLOCK LABEL

FINAL PLAT
FOR
TIMBER OAKS
SUBDIVISION
Block 1, Lots 1-30
Block 2, Lots 31-55
Being a total of 12.192 acres out of the
T.J. Wooten Survey, A-59
City Of Bryan, Brazos County, Texas

Colliers Engineering & Design
www.colliersengineering.com
Doing Business as MASER
811 PROTECT YOURSELF

Table with columns: DATE, DRAWN BY, DESCRIPTION, REV.

Table with columns: DATE, DRAWN BY, DESCRIPTION, REV.

Table with columns: DATE, DRAWN BY, DESCRIPTION, REV.

FINAL PLAT
FOR
TIMBER OAKS
SUBDIVISION
T.J. WOOTEN SURVEY, A-59
CITY OF BRYAN,
BRAZOS COUNTY, TEXAS

Colliers Engineering & Design
4500 Rattiff Lane, Suite 113
Addison, TX 75001
Phone: 214.613.1204
COLLIERS ENGINEERING & DESIGN, INC.
DOING BUSINESS AS MASER CONSULTING
OWNER/DEVELOPER: JESSE C. WALL III, 8702 ADAMS LANE, TEMPLE, TX 76702, 254-721-6179
SURVEYOR / ENGINEER: COLLIERS ENGINEERING & DESIGN, 4500 RATLIFF LANE #113, ADDISON, TEXAS 75001, 214-613-1204